

# Machines Devices



## PCB processing

PCB separators.....	504
Off-cut remover.....	510

## Component Processing

Axial components.....	512
Radial components.....	516
Pneumatic cutting machines.....	519
Cut-off saw.....	521

## Counting devices / balances

Component counting devices.....	521
Component counting balances.....	523

## PCB separators

### MAESTRO 2 / 2M

#### MAESTRO 2 manual / MAESTRO 2 M with motor

The compact MAESTRO 2 separates PCBs in a quick and economical way, needs only a small work space.



#### MAESTRO 2

The inexpensive entry-level model for the small demand. The PCB is manually fed between the circular blades and separated.

#### MAESTRO 2 M with motor

Separates larger quantities without fatigue. The lower circular blade is driven by a motor. The PCB is inserted, the circular blade seizes, transports and separates it. Three speeds can be chosen.

#### Strain of the components

For critical components an upper limit of the tensile stress is often determined. Please ask us for the possibilities to reduce the tensile stress of the component.

#### Safe handling

The PCB is inserted and separated. The distance between the upper guide **1** and the lower guide **2** is set so low that the PCB can only be fed in the pre-scored groove.

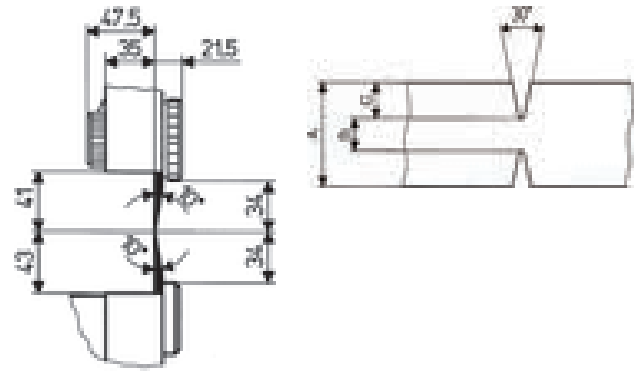

- Maximum height of the component on the pre-scored groove.
- The pre-scored groove can be interrupted by cut-outs of up to 5 mm length.

#### PCB

PCB thickness A:	0.8 - 3.2 mm
Remaining thickness B typical:	1/3 of size A, max. 0.8 mm
Depth of scoring C:	min. 0.25 mm
Extension of the external dimensions after the separation:	0.1 - 0.2 mm

#### Technical data

Separation principle:	Component side: circular blade Solder side: circular blade
Separation process:	MAESTRO 2 manual MAESTRO 2 M motor drive
Separation speed:	2M 100/200/300 mm / sec.
Cutting length:	15-300 mm
Supply voltage:	switchable, 2M 230/115 V ^ 50-60 Hz
Grounding push button:	Ø 10 mm
Operating temperature:	10 - 35°C
Storage / transport temperature:	20 - 50°C
Humidity non-condensing:	10 - 85 %
Safety requirements:	CE, FCC class 1
Weight:	MAESTRO 2 16 kg MAESTRO 2 M 19 kg
Dimensions H x W x D:	330 x 195 x 620 mm

The products meet the safety requirements of the EC directives. An EC declaration of conformity is supplied with the devices.

#### MAESTRO 2 MAESTRO 2M

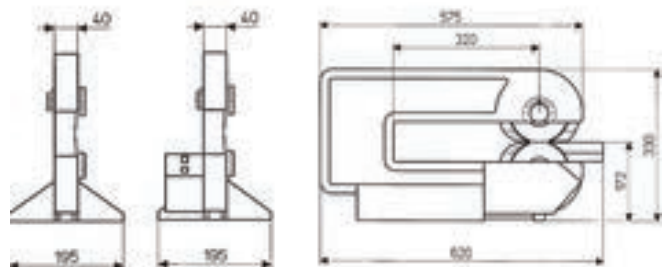

#### dpmlink 5393

Article	Type
8933900	PCB separator MAESTRO 2, manual
8933935	PCB separator MAESTRO 2 M, with motor



## MAESTRO 3E

### MAESTRO 3E

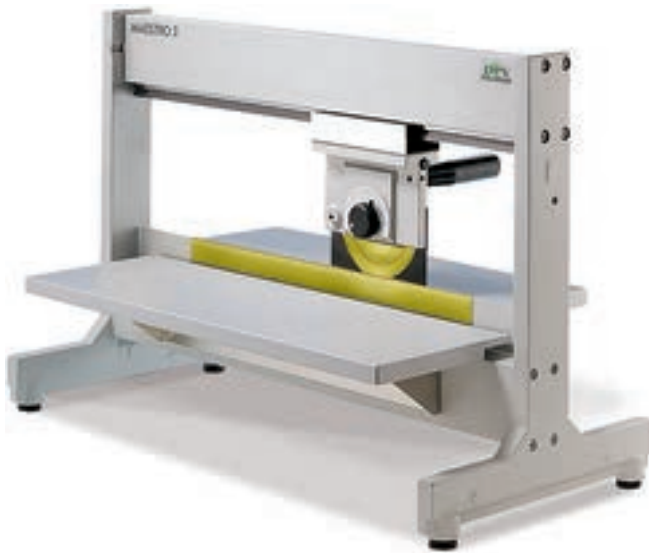

The MAESTRO 3E separates large and small PCBs. The table and the rest are steplessly adjustable to the best working position. The distance between linear blade and the rest can be adjusted in such a way that the edge strips fall through and sorted out.

#### Strain of the components

For critical components an upper limit of the tensile stress is often determined. Please ask us for the possibilities to reduce the tensile stress of the component.

#### Safe handling

The PCB is placed with the pre-scored groove onto the linear blade. The circular blades are drawn by hand across the PCB. The distance between the upper guide and the linear blade is adjusted in such a way that the PCB can only be separated in the pre-scored groove.



The pre-scored groove can arbitrarily be interrupted by cut-outs.

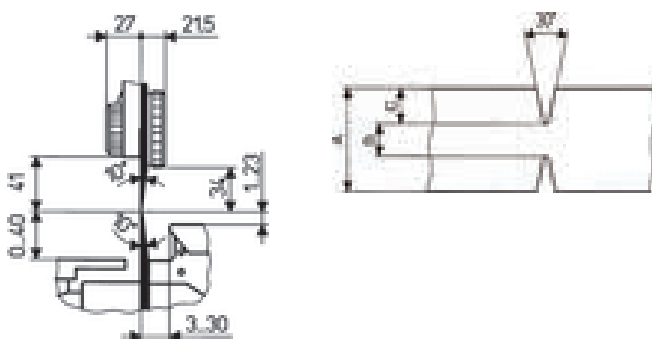

For protruding parts the linear blade must be recessed. Request if necessary.

#### PCB

PCB thickness A:	0.8 - 3.2 mm
Remaining thickness B typical:	1/3 of size A, max. 0.8 mm
Depth of scoring C:	min. 0.25 mm
Extension of the external dimensions after the separation:	0.1 - 0.2 mm

#### Technical data

Separation principle:	Component side: circular blade Solder side: linear blade
Separation process:	manual
Cutting length:	max. 450 mm
Grounding push button:	Ø 10 mm
Operating temperature:	10 - 35°C
Storage / transport temperature:	20 - 50°C
Humidity non-condensing:	10 - 85 %
Safety requirements:	CE, FCC class 1
Weight:	22 kg
Dimensions H x W x D:	455 x 350 x 700 mm

The products meet the safety requirements of the EC directives. An EC declaration of conformity is supplied with the devices.

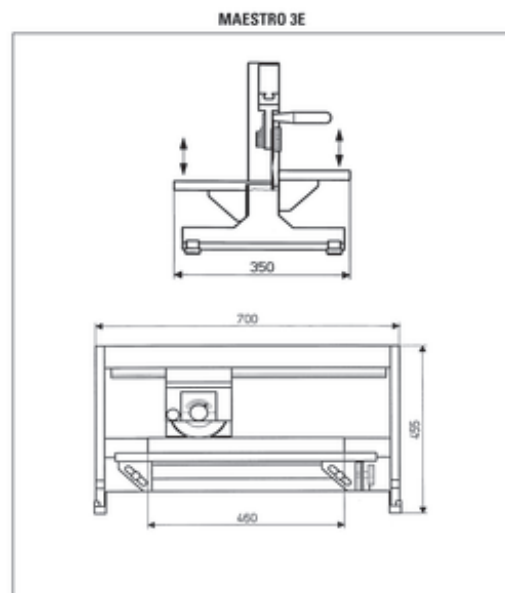

[dpmlink 5471](#)

Article 8933945 Type **PCB separator MAESTRO 3E / 450 manual**  
Cutting length of max. 450 mm



## MAESTRO 4S

### MAESTRO 4S



#### Stressless cutting of pre-scored PCBs

MAESTRO 4S meets your expectations of versatility for the following requirements:

- Directly to the pre-scored groove there are sensitive equipped components
- You cut PCBs with a width of up to 3.2 mm
- Aluminium PCBs have to be cut

The PCB separator MAESTRO 4S moves across the pre-scored groove in up to five operation steps. During this procedure the distance of the blades is reduced in programmable steps between 0.6 mm and 0.05 mm. Up to eight programs can be stored in the control panel.

Moving across the pre-scored groove for several times minimizes tensile and pressure and thus the danger that sensitive components located near the pre-scored groove are damaged. Thick PCBs of FR4 or aluminium are cut without rest by this procedure.

Increasing the factory-set blade distance by 0.1 mm already reduces the tensile and pressure strength by 50 %. Increasing the mm, the stress is minimized by more than 10 times

#### Technical data:

Separation principle	component side: circular blade solder side: linear blade
Separation process	optimized, motorized
Separation speed	300, 500 mm/s, switchable
Materials	FR4, aluminium
Height of component	component / solder side up to 34 mm
Separation length	up to 450 mm (model 4S / 450) up to 600 mm (model 4S / 600)
Depth of support table	200 mm
Voltage	100 - 240 VAC, 50/60 Hz
Emission sound pressure level	LpA < 70 dB (A)
Temperature / operation	+ 10 - 35°C / 10 - 85 %
Humidity storage	0 - 60°C / 20 - 80 %
not condensing transport Transport	- 25 - 60°C / 20 - 80 %
Width x height x depth	702 x 434 x 425 mm (model 4S / 450) 852 x 434 x 425 mm (model 4S / 600)
Weight	38 kg (model 4S / 450) 46 kg (model 4S / 600)
Approvals	CE, FCC Class A

#### Programming

Start	Go to start position
Programs	9
Separating steps	1 - 5
Blade distance	0.9 - 0.05 mm
Key button	Unlock program selection
Display cutting performance	up to 99 km
DEL	Reset the steps
Power switch	ON/OFF
Foot switch	START separation process
Safety swith	Emergency stop

#### dpvlink 17676







Article	Type
8936800	<b>PCB separator MAESTRO 4S / 450</b> with motor drive, cutting length 450 mm with upper circular blade for FR4 PCBs (art.Nr. 8930509)
8936800-ALU	<b>PCB separator MAESTRO 4S / 450</b> with motor drive, cutting length 450 mm with circular blade for aluminium PCBs (art.Nr. 8936895)
8936745	<b>PCB separator MAESTRO 4S / 600</b> with motor drive, cutting length 600 mm with upper circular blade for FR4 PCBs (art.Nr. 8930509)
8936745-ALU	<b>PCB separator MAESTRO 4S / 600</b> with motor drive, cutting length 600 mm with circular blade for aluminium PCBs (art.Nr. 8936895)
8931240	<b>Conveyor belt for MAESTRO 4S/450</b>

## Accessories / spare parts for MAESTRO

### Spare parts Maestro 2 / 2M



Spare parts	
	8930501.03-DPV <b>Upper circular blade type 03 / in-line DPV</b> with titanium coating for FR4 PCBs
	8930509 <b>Upper circular blade "Ti"</b> with titanium coating for FR4 PCBs
	8933661 <b>Lower circular blade "Ti"</b> with titanium coating
	8930744 <b>Protection upper blade</b>
	8930745 <b>Protection lower blade</b>

## Accessories / spare parts MAESTRO 3E



### Spare parts



8930501.03-DPV **Upper circular blade type 03 / in-line DPV**  
with titanium coating  
for FR4 PCBs



8930509 **Upper circular blade "Ti"**  
with titanium coating  
for FR4 PCBs



8933394 **Linear blade 450 "Ti"**



8930602 **Protection 1 / to serial no. 1999**



8936614 **Protection 1 / from serial no. 2000**



8930603 **Protection 2 / to serial no. 1999**



8936615 **Protection 2 / from serial no. 2000**

### Accessories



8970208 **Measuring device**

## Accessories / spare parts MAESTRO 4M and 4S



### Spare parts



8930501.03-DPV **Upper circular blade type 03 / in-line DPV**  
with titanium coating  
for FR4 PCBs



8930509 **Upper circular blade "Ti"**  
with titanium coating  
for FR4 PCBs



8936895 **Upper circular blade "Ti"**  
with titanium coating  
for aluminium PCBs



8933394 **Linear blade 450 "Ti"**



8933931 **Linear blade 450 clean "Ti"**  
for MAESTRO 4M / 450 clean



8930602 **Protection 1 / to serial no. 1999**



8936614 **Protection 1 / from serial no. 2000**



8930603 **Protection 2 / to serial no. 1999**



8936615 **Protection 2 / from serial no. 2000**



8933933 **Circular blade upper 4M / 70 "Ti"**  
Passage height 70 mm

### Accessories



8970208 **Measuring device**

## Spare parts MAESTRO 6



[dpvlink 21957](#)



Article	Type
8936446	<b>Circular blade 60 FR4</b>
8936507	<b>Circular blade 60 ALU</b>
8933682	<b>Linear blade 600</b> Titanium/Nitrite linear blade for Maestro 3, Maestro 4 and Maestro 6
8936480	<b>Measuring device 6/x03</b>

## MAESTRO 6

### MAESTRO 6

**cab**



#### PCB Separator MAESTRO 6 for separating pre-scored PCBs

MAESTRO 6 is a further development of the previous CAB PCB separators and can be used to separate PCBs up to 1,200 mm in length in an easy and efficient way and with a minimum of stress on the material. The separation and removal is optimally possible as the power unit of the carriage is right behind the linear blade.

#### Features:

- individually adjustable circular blades
- separation length steplessly adjustable
- ergonomic support table
- indication of the cutting performance

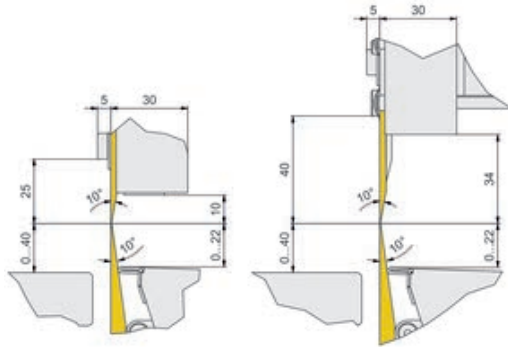

#### Operating keys

- Move carriage to initial position
- Separation length adjustment:
  - PCB separation in two steps
  - PCB separation in three steps
- Separation speed adjustment
- Indication of total cuts (up to 9999)
- Indication of total separation length (up to 9999 km)
- "Emergency stop" safety switch
- Foot switch to start separation



#### Technical data:

Model	6/603	6/903	6/1203
Separation principle component side / solder side	3 circular blades / linear blades		
Separation process	optimized		
Separation speed	up to 500 mm / s		
Material	FR4, CEM3, aluminum		
Height of component component side / solder side	up to 16 mm		
Separation length up to	600 mm	900 mm	1200 mm
Depth of support table	200 mm		
Voltage	100 - 240 VAC, 60 / 60 Hz		
Emission sound pressure level	LpA < 70 dB (A)		
Temperature / humidity operation	+ 5 °C - 40 °C / 10 - 85 % not condensing		
Temperature / humidity storage	+ 0 °C - 60 °C / 20 - 80 % not condensing		
Temperature / humidity transport	-25 °C - 60 °C / 20 - 80 % not condensing		
Weight	40 kg	45 kg	50 kg
Height x depth	350 x 450 mm		
Width	1150 mm	1450 mm	1750 mm
Approvals	CE, FCC, class A		

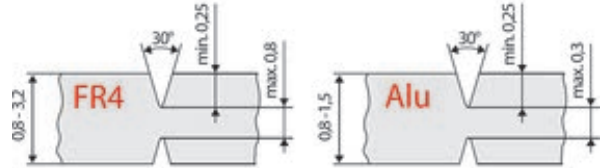

The pre-scored groove can be interrupted by cut-outs.

Typical 0.2 mm extension of the external dimensions after the separation.

#### dpvlink 21949



Article	Type
8936510	<b>PCB separator MAESTRO 6 / 603</b> with motor drive, cutting length 600 mm with 3 circular blades in the upper part for FR4 PCBs
8936510-ALU	<b>PCB separator MAESTRO 6 / 603</b> with motor drive, cutting length 600 mm with 3 circular blades in the upper part for aluminum PCBs
8936500	<b>PCB separator MAESTRO 6 / 903</b> with motor drive, cutting length 900 mm with 3 circular blades in the upper part for FR4 PCBs
8936500-ALU	<b>PCB separator MAESTRO 6 / 903</b> with motor drive, cutting length 900 mm with 3 circular blades in the upper part for aluminum PCBs
8936490	<b>PCB separator MAESTRO 6 / 1203</b> with motor drive, cutting length 1200 mm with 3 circular blades in the upper part for FR4 PCBs
8936490-ALU	<b>PCB separator MAESTRO 6 / 1203</b> with motor drive, cutting length 1200 mm with 3 circular blades in the upper part for aluminum PCBs
8936570	<b>PCB separator MAESTRO 6 / 1503</b> with motor drive, cutting length 1500 mm with 3 circular blades in the upper part for FR4 PCBs
8936570-ALU	<b>PCB separator MAESTRO 6 / 1503</b> with motor drive, cutting length 1500 mm with 3 circular blades in the upper part for aluminum PCBs

## MAESTRO 5L

### MAESTRO 5L

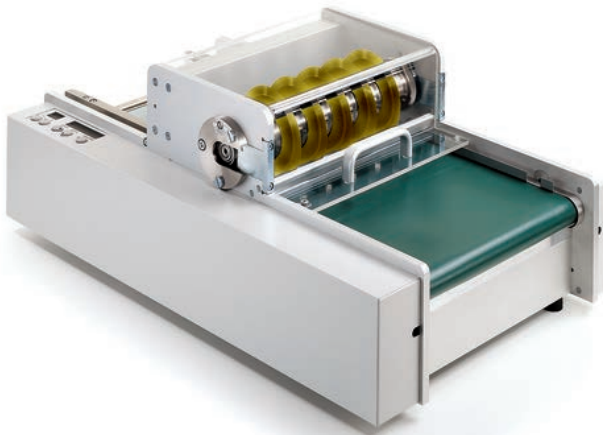

#### Strain of the components

For critical components an upper limit of the tensile stress is often determined. Please ask us for the possibilities to reduce the tensile stress of the components.

#### MAESTRO 5L

It is an economical machine if large quantities of pre-scored PCBs are separated. Easy handling with the clear control panel. Up to 10 circular blades separate the PCBs, with a width to 310 mm, at the same time. Sensors monitor the separation process. The panels are inserted manually or are automatically fed by a loading station. The installation in an assembly line is also possible. Provided by default: the SMEMA interface. The PCB separator MAESTRO 5L will be adapted to your PCB size and your requirements. Panel widths larger than 310 mm are available on request. A display shows the separation speed, cutting length, and number of panels.

#### Adjustment

The distance between the upper and lower circular blades is precisely adjusted via an eccentric. If service is needed, both shafts with mounted circular blades are simply removed.



Messerwellen

The width of the PCB feeder can be adjusted precisely. The distance of the upper to the lower circular blade is adjusted with a fine thread on the shaft.



MAESTRO 5L mit Untergestell

With an additional conveyor belt for processing of the individual PCBs after the separation.

The conveyor belts, the circular blades and the drive are installed in a robust aluminium housing. The max. panel width is up to 310 mm in case of MAESTRO 5L. Larger PCBs available on request.



#### Safe handling

The handling is easy and comfortable. The feeding of the PCB takes place by hand or automatically within the assembly line, or by a loading station located in front of the line.

The separated PCBs are received by a conveyor belt. Dividers and edge strips fall through into the container below.

From the conveyor belt, the PCBs are taken by hand or passed to a following transport unit for further processing.

A light barrier at the end of the transport distance prevents an unintentional falling of the PCBs.

#### Gentle separation

The PCB is separated with nearly zero potential due to the special sharpening of the circular blades.

The distance of the circular blade is adapted with spacer rings to the PCB width according to customer's requirements.

#### PCB

A PCB thickness:	1.0 - 3.2 mm
B remaining PCB thickness:	min. 0.30 mm typical 1/3 of size A max. 0.60 mm
C depth of scoring:	min. 0.30 mm
Extension of the external dimensions after the separation:	0.1 - 0.2 mm

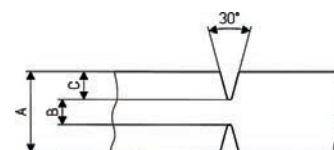

#### Technical data

Separation principle:	top circular blade, bottom circular blade
Separation process:	Motor drive
Separation speed:	100-220 mm / sec. adjustable in 10 steps
Cutting length:	with activated light barrier 100-570 mm with deactivated light barrier > 100 mm
Width off-cut:	min. 3 mm
Component height / component side:	max. 30 mm
Component height / solder side:	max. 10 mm
Number of circular blades:	up to 10
Panel width:	up to 310 mm
PCB width:	10-290 mm
Supply voltage:	switchable 115/230 V ^ 50-60 Hz
Operating temperature:	10°C to 35°C
Storage / transport temperature:	-20°C to 50°C
Humidity non-condensing:	10% to 85%
Weight:	63 kg

The devices meet the safety requirements of the EC directives. An EC declaration of conformity is supplied with the devices.

MAESTRO 5L with control light (Note: control light is included in the standard scope of delivery.)

**Scope of delivery:**

- Maestro 5L with base frame
- Number of circular blades as requested
- Support and holder handles
- Adjustment device for blade change

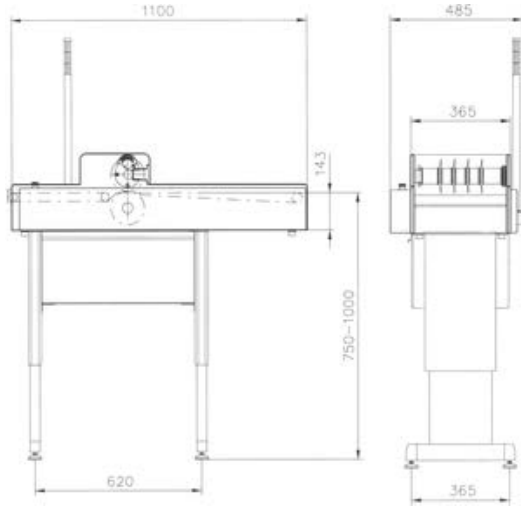

[dpvlink 5663](#)



Article	Type
8934520	<b>MAESTRO 5L</b> PCB separator MAESTRO 5L standard version including construction, clean version, cleaning brushes and second SMEMA, bottom guide, blade covering, putting into operation and training, <b>without blade shaft pair</b>
893XXX.MW2	<b>Blade shaft pair with 2 blades "Ti"</b> and spacer rings for PCBs with 1 pre-scored groove
893XXX.MW4	<b>Blade shaft pair with 4 blades "Ti"</b> and spacer rings for PCBs with 2 pre-scored grooves
893XXX.MW6	<b>Blade shaft pair with 6 blades "Ti"</b> and spacer rings for PCBs with 3 pre-scored grooves
893XXX.MW8	<b>Blade shaft pair with 8 blades "Ti"</b> and spacer rings for PCBs with 4 pre-scored grooves
893XXX.MW10	<b>Blade shaft pair with 10 blades "Ti"</b> and spacer rings for PCBs with 5 pre-scored grooves
893XXX.MW12	<b>Blade shaft pair with 12 blades "Ti"</b> and spacer rings for PCBs with 6 pre-scored grooves
893XXX.MW14	<b>Blade shaft pair with 14 blades "Ti"</b> and spacer rings for PCBs with 7 pre-scored grooves
893XXX.MW16	<b>Blade shaft pair with 16 blades "Ti"</b> and spacer rings for PCBs with 8 pre-scored grooves
893XXX.MW18	<b>Blade shaft pair with 18 blades "Ti"</b> and spacer rings for PCBs with 9 pre-scored grooves
893XXX.MW20	<b>Blade shaft pair with 20 blades "Ti"</b> and spacer rings for PCBs with 10 pre-scored grooves

**Accessories / spare parts MAESTRO 5L**



[dpvlink 5670](#)



Article	Type
8934803	<b>Circular blade / replacement blade "Ti" MAESTRO 5 I / W</b>

**Off-cut remover**

**Off-cut remover Hektor**

**Off-cut remover Hektor 2**



Hektor separates milled PCBs carefully and fast. The off-cuts are separated smoothly and precisely.

The two-part matrix ensures an easy and cost-saving mounting or change of the differently wide blades.

Compressed air cylinder is used for the separation process. The operation pressure can be set on the device. The punching process is actuated by pressing the foot switch.

The off-cuts are collected in the container. When the gate is open, the waste can be removed.



**Safe handling**

The PCB is placed with the milled groove over the blade onto the matrix. The material is pushed under the punching blade.

By pressing the foot switch, the cut-off is punched and collected in the box.

**Blades**

The blades are made of special steel. Each version is available in 5 standard widths. In order to prevent a jamming of the blade in the PCB, the blade should be at least 0.15 mm narrower than the milling slot. Intermediate sizes are manufactured according to customer's specifications.

The L-shaped blade is used if there are small off-cut distances.

Off-cuts right and left of the edge are punched out with the T-shaped blade. A turning of the PCB is not necessary.



[dpvlink 5547](#)



Article	Type
8932145	<b>Off-cut remover Hektor 2</b> <b>Scope of delivery:</b> Hektor 2 with pressure regulator, foot switch, without blade

**- please order blades separately -**



## Blades for Hektor 2



### Technical data

Separation principle:	Punching blade
PCB thickness:	up to 2.5 mm
Air connection:	1/4" coupling socket
Operating pressure:	typical 4 bar
Operating mode:	pneumatic
Operating temperature:	15 - 35°C
Storage / transport temperature:	20 - 50°C
Non-condensing humidity:	10 - 85 %
Weight Hektor 2:	2.7 kg
Dimensions H x W x D	170 x 220 x 255 mm

Safety requirements: CE, FCC class 1. Subject to technical modifications.

A = milled groove width	E = component-free solder side
B = recommended thickness of blade	F = milled groove length
C = blade length	G = off-cut width
D = cutting length	

Description	Art.Nr.	A	B	C	D	E	F	G
Blade T1.3	8932194	≥1.3	1.15	17.2	4.7	>19.0	>19.0	2.5
Blade T1.4	8932196	≥1.4	1.25	17.2	4.7	>19.0	>19.0	2.5
Blade T1.5	8932137	≥1.5	1.35	17.2	4.7	>19.0	>19.0	3.0
Blade T2.0	8932138	≥2.0	1.85	17.2	5.2	>19.0	>19.0	3.0
Blade T2.2	8932195	≥2.2	2.05	17.2	5.2	>19.0	>19.0	3.0
Blade T2.3	8932197	≥2.3	2.15	17.2	5.2	>19.0	>19.0	3.0
Blade T2.4	8932191	≥2.4	2.25	18.0	5.7	>19.0	>19.0	3.0
Blade T2.5	8932139	≥2.5	2.35	18.0	5.7	>19.0	>19.0	3.0
Blade T3.0	8932144	≥3.0	2.85	18.0	5.7	>19.0	>19.0	2.5
Blade L1.5	8932122	≥1.5	1.35	12.0	4.7	>15.0	>13.0	3.0
Blade L2.0	8932123	≥2.0	1.85	12.0	5.2	>15.0	>13.0	3.0
Blade L2.1	8932198	≥2.1	1.95	12.0	5.2	>15.0	>13.0	3.0
Blade L2.3	8932193	≥2.3	2.15	12.0	5.7	>15.0	>13.0	3.0
Blade L2.4	8932141	≥2.4	2.25	12.0	5.7	>15.0	>13.0	3.0
Blade L2.5	8932124	≥2.5	2.35	12.0	5.7	>15.0	>13.0	3.0
Blade L3.0	8932125	≥3.0	2.85	12.0	5.7	>15.0	>13.0	2.5
Blade L3.2	8932127	≥3.2	3.05	12.0	5.7	>15.0	>13.0	2.5

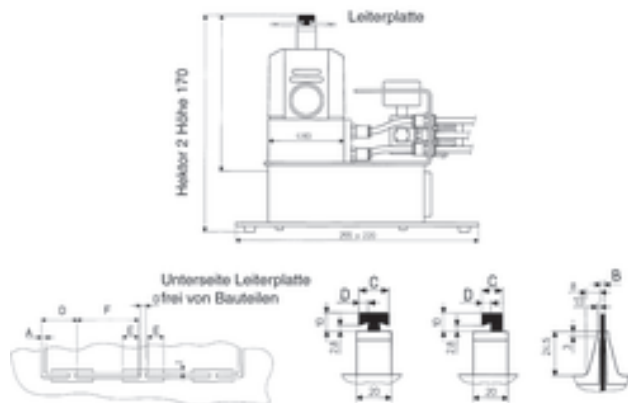

dpvlink 5554

Article	Type
<b>Blades for Hektor 2</b>	
8932122	Blade L 1.5 standard
8932123	Blade L 2.0 standard
8932141	Blade L 2.4 standard
8932124	Blade L 2.5 standard
8932125	Blade L 3.0 standard
8932137	Blade T 1.5 standard
8932138	Blade T 2.0 standard
8932191	Blade T 2.4 standard
8932139	Blade T 2.5 standard
8932144	Blade T 3.0, standard
89321XX	Blade width, according to customer's specifications
8932171	Matrix for Hektor 2 (precision casting)



## Off-cut remover DPP

### Off-cut remover DPP



Pneumatic off-cut remover DPP

This handy off-cut remover allows the quick separation of milled PCBs. The compact size allows the cutting even in difficult to reach places. The off-cuts are removed cleanly and smoothly.

The blades are made of a special steel. Four blade thicknesses are available.

### Technical data

Compressed air supply:	5-6 bar
Cutting power of the cylinder:	393 N (40 kg)

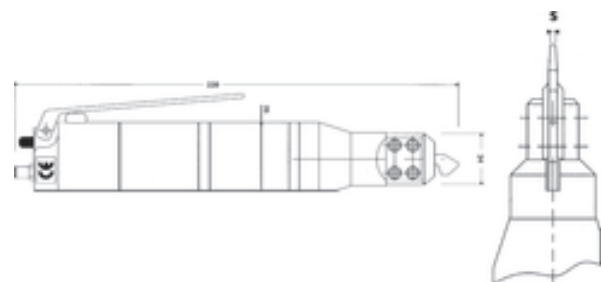

dpvlink 5610

Article	Type
DPP-18N	<b>Off-cut remover DPP 18N</b> Blade width s = 1.8 mm
DPP-20N	<b>Off-cut remover DPP 20N</b> Blade width s = 2.0 mm
DPP-23N	<b>Off-cut remover DPP 23N</b> Blade width s = 2.3 mm
DPP-24N	<b>Off-cut remover DPP 24N</b> Blade width s = 2.4 mm
DPP-25N	<b>Off-cut remover DPP 25N</b> Blade width s = 2.5 mm
DPP-Set	<b>Off-cut remover DPP set incl. case</b> Blade width s = 2.0 / 2.3 / 2.4 / 2.5 mm



## Blade set (blade and matrix)



**dpvlink 5616**



Article	Type
DPP-SET18	Blade set for DPP s = 1.8 mm
DPP-SET20	Blade set for DPP s = 2.0 mm
DPP-SET23	Blade set for DPP s = 2.3 mm
DPP-SET24	Blade set for DPP s = 2.4 mm
DPP-SET25	Blade set for DPP s = 2.5 mm

## Single blades



**dpvlink 5621**



Article	Type
DPP-L18	Blade for DPP s = 1.8 mm
DPP-L20	Blade for DPP s = 2.0 mm
DPP-L23	Blade for DPP s = 2.3 mm
DPP-L24	Blade for DPP s = 2.4 mm
DPP-L25	Blade for DPP s = 2.5 mm

## Off-cut remover DP manual

### Off-cut remover (manual)



This handy off-cut remover tool allows the quick separation of milled PCBs.

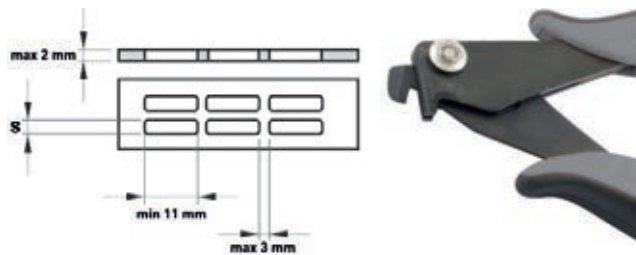

**dpvlink 5626**



Article	Conductivity	S [mm]
<b>Off-cut remover (manual)</b>		
DP-10N.D	dissipative	1,0
DP-15N.D	dissipative	1,5
DP-20N.D	dissipative	2,0
DP-23N.D	dissipative	2,3
DP-24N.D	dissipative	2,4
DP-25N.D	dissipative	2,5

## Axial components

### CUTBEND

#### Cutting and bending machine for axial components

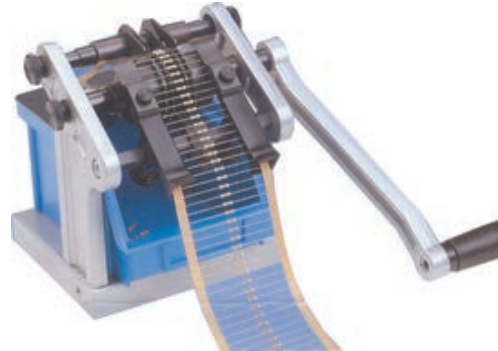

A "successive cutting" of the component wire prevents an axial tensile stress on sensitive parts (e.g. diodes). By loosening one screw, the cutting and bending wheel is released and can be moved into the right position by sliding. With the adjustment knob grid dimensions can be transferred directly from the PCB to the machine, which reduces considerably the setting time.

#### Technical data

Dimensions without crank:	175 x 145 x 160 mm (LxWxH)
Crank length:	160 mm
Weight:	1.9 kg
Performance:	up to 40,000 components per hour



**VB** Standardausrüstung  
Beidseitig Schneiden und Biegen  
(VB-Kopf)

**BG** Eine Seite Schneiden und Biegen  
(1/2 VB-Kopf), andere Seite nur Schneiden  
(1/2 FG-Kopf) = BG-Kopf

**FG** Beidseitig nur Schneiden =  
FG-Kopf

#### Processing possibilities

Type	A	B	C	D	E
VB05	0.3 - 0.5	4.7 - 40	mind. 1,0	2.6 - 15	-
<b>VB08*</b>	<b>0.5 - 0.8</b>	<b>6.0 - 40</b>	<b>mind. 1.3</b>	<b>3.6 - 15</b>	-
VB10	0.9 - 1.0	6.0 - 40	mind. 1.8	3.6 - 15	-
VB12	1.1 - 1.2	6.0 - 40	mind. 2.0	3.6 - 15	-
<b>FG08*</b>	<b>0.5 - 0.8</b>	-	-	-	<b>3.1 - 20</b>
<b>BG08*</b>	<b>0.5 - 0.8</b>	-	<b>mind. 1.0</b>	<b>3.6 - 15</b>	<b>3.1 - 20</b>

\*Standard devices



## Loose component feeder CB-3000

Feeder for loose components. Two adjustable feed rolls unravel and center the components and feed them into the CUTBEND. Feeding up to 3000 components per hour.



## Dispenser reel CB-109

This dispenser reel facilitates the feeding of taped components into the CUTBEND. It can easily be mounted on the device.

### dpvlink 5085

Article Type

405.100	<b>CUTBEND type (VB 08) standard, complete device</b>
405.101	<b>CUTBEND type (VB 05), complete device</b>
405.105	<b>CUTBEND type (VB 10), complete device</b>
405.106	<b>CUTBEND type (VB 12), complete device</b>
405.115	<b>CUTBEND type (FG 08) standard, complete device</b>
405.120	<b>CUTBEND type (BG 08) standard, complete device</b>



### dpvlink 5095

Article Type

405.200	<b>Wheel set - type (VB 08) standard</b>
405.201	<b>Wheel set - type (VB 05)</b>
405.205	<b>Wheel set - type (VB 10)</b>
405.206	<b>Wheel set - type (VB 12)</b>
405.215	<b>Wheel set - type (FG 08)</b>
405.220	<b>Wheel set - type (BG 08)</b>
405.250	<b>Replacement blade for VB 05 / VB 08</b>
405.251	<b>Replacement blade for VB 10 / VB 12</b>
405.300	<b>Dispenser reel CB-109, taped components</b>
405.310	<b>Feeder CB-3000, for loose components</b>



-further spare parts available on request-

## TP 6-EC - OLAMEF

### Cutting and bending machine for axial components

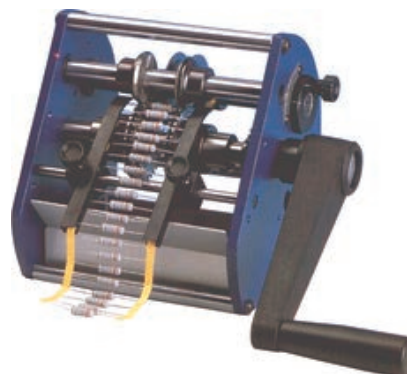

simple construction, no protective cover, no motor connection possible

With the cutting and bending machine TP 6-EC, taped axial components can be cut and bent. Components with leads up to a diameter of 1.3 mm can be processed. The setting of various dimensions is quick and easy.

#### Technical data

Performance:	approx. 50,000 components per hour
Dimensions:	230 x 180 x 210 mm
Weight:	5 kg

#### TP 6/1.EC - Standard

	P	B	c	L	d	D
Min. mm	6.5	4	1.2	-	0.4	0.4
Max. mm	60	13	-	50	1.3	16



#### TP 6/6.EC - reduced pitch

	P	B	c	L	d	D
Min. mm	5.08	4	0.8	-	0.4	0.4
Max. mm	60	13	-	50	0.8	10

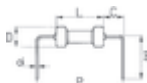

#### TP 6/7.EC - fixed pitch P = 5.08 mm

	P	B	c	d	D
Min. mm	5.08	4	0.5	0.4	0.4
Max. mm	fixed	10	-	0.6	4



#### TP 6/4.EC - for wire thicknesses up to 1.4 mm

	P	B	c	L	d	D
Min. mm	10.16	5	2.4	-	0.6	0.6
Max. mm	60	13	-	50	1.4	16

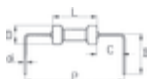

### dpvlink 5110

Article Type

415.100.EC	<b>TP 6/1.EC - standard</b> for wire thicknesses $\varnothing$ 0.4 - 1.3 mm
415.101.EC	<b>TP 6/6.EC - reduced pitch</b> for wire thicknesses $\varnothing$ 0.4 - 0.8 mm
415.102.EC	<b>TP 6/7.EC - fixed pitch P = 5.08 mm</b> for wire thicknesses $\varnothing$ 0.4 - 0.8 mm
415.103.EC	<b>TP 6/4.EC - reinforced bending wheels</b> for wire thicknesses $\varnothing$ 0.6 - 1.4 mm



## TP 6 / V-EC - OLAMEF

Cutting and bending machine for axial components, standing assembly



simple construction, no protective cover, no motor connection possible

With the cutting and bending machine TP 6/V-EC taped axial components for standing mounting can be cut and bent. The robust construction of the machine ensures a high level of reliability. Components with leads up to a diameter of 0.8 mm can be processed. Different bending tools are used for different grid dimensions. The fine tuning of the grid dimensions is done via a knurled screw.

### Technical data

Performance:	spprox. 50,000 components per hour
Dimensions:	230 x 180 x 210 mm
Weight:	5 kg

### TP 6/V-EC - Standard P = 2.54 mm

	P	L	F	D	d	A
Min. mm	2.54	-	3	0.5	0.5	2
Max. mm	fixed	15	8	3	0.8	6

### TP 6/V1 - with bending tool P = 3.8 mm

	P	L	F	D	d	A
Min. mm	3.8	-	3	0.5	0.5	2.5
Max. mm	fixed	15	8	3	0.8	6

### TP 6/V1 - with bending tool P = 5.08 mm

	P	L	F	D	d	A
Min. mm	5.08	-	3	0.5	0.5	3
Max. mm	fixed	15	8	8	0.8	7

### dpvlink 5117

Article Type

415.400.EC **TP 6/V1.EC - standard standing assembly**

#### Accessories

415.430.V1 **Additional bending tool P = 3.8 mm**  
standing assembly

415.435.V1 **Additional bending tool P = 5.08 mm**  
standing assembly

415.439 **Holder for additional bending tool**  
(for an easy conversion)



## TP 6 • TP 6.97 - OLAMEF

Cutting and bending machine for axial components, version type 97 with simplified bending wheel adjustment



Cutting and bending machine TP 6.97 standard

With the cutting and bending machine TP 6 taped axial components can be cut and bent. The robust construction of the machine ensures a high level of reliability.

Components with leads up to a diameter of 1.3 mm can be processed. The setting of various dimensions is quick and easy.

### Version TP 6 /...97

The TP 6 /...97 is in addition equipped with a simplified bending wheel adjustment reducing considerably the set-up times.

### Technical data

Performance:	approx. 50,000 components per hour
Dimensions:	230 x 180 x 210 mm
Weight:	5 kg

## TP 6/1 • TP 6/1.97 standard



### TP 6 - Standard

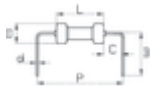

	P	B	c	L	d	D
Min. mm	6.5	4	1.2	-	0.4	0.4
Max. mm	60	13	-	50	1.3	16

### dpvlink 5141

Article Type

415.100 **TP 6/1 - standard**  
for wire thicknesses Ø 0.4 - 1.3 mm

415.100.97 **TP 6/1.97 - standard**  
with simplified bending wheel adjustment,  
for wire thicknesses Ø 0.4 - 1.3 mm



## TP 6/6 • TP 6/6.97 reduced pitch



### TP 6/6 - reduced pitch



	P	B	c	L	d	D
Min. mm	5.08	4	0.8	-	0.4	0.4
Max. mm	60	13	-	50	0.8	10

#### dpvlink 5153

Article Type

415.101 **TP 6 / 6 - reduced pitch**  
for wire thicknesses Ø 0.4 - 0.8 mm

415.101.97 **TP 6 / 6.97 - reduced pitch**  
with simplified bending wheel adjustment,  
for wire thicknesses Ø 0.4 - 0.8 mm



## TP 6/7 fixed pitch



### TP 6/7 - fixed pitch P = 5.08 mm

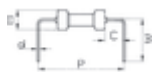

	P	B	c	d	D
Min. mm	5.08	4	0.5	0.4	0.4
Max. mm	-	10	-	0.6	4

#### dpvlink 5156

Article Type

415.102 **TP 6 / 7 - fixed pitch P = 5.08 mm**  
for wire thicknesses Ø 0.4 - 0.6 mm

415.102.400713 **additional bending wheel**  
fixed grid P 7.62 mm

415.102.400714 **additional bending wheel**  
fixed grid P = 10.16 mm



## TP 6/4 • TP 6/4.97 reinforced bending wheels



### TP 6/4 - reinforced bending wheels

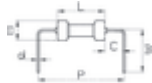

	P	B	c	L	d	D
Min. mm	10.16	5	2.4	-	0.6	0.6
Max. mm	60	13	-	50	1.4	16

#### dpvlink 5160

Article Type

415.103 **TP 6 / 4 - reinforced bending wheels**  
for wire thicknesses Ø 0.6 - 1.4 mm

415.103.97 **TP 6 / 4.97 - reinforced bending wheels**  
with simplified bending wheel adjustment,  
for wire thicknesses Ø 0.6 - 1.4 mm



#### Accessories

415.800 **BR6 reel holder**



415.805 **CS 10 feeding unit / loose components**  
(for TP6, TP6 / PR-B, TP6 / S)



415.825 **M adjustable motor drive**



415.835.1 **TNS/1 waste tape ejector**  
(for TP/6, TP6/S, TP6/V, TP6/PR-B, TP6/R)



415.200240 **Feeder / component body type 200240**  
for taped components suitable for  
TP 6.ÉC; TP 6.97; TP6 PR-B;  
TP6 / PR-B/97; TP 6/S; TP6



## TP 6 / V - OLAMEF

### Cutting and bending machine for axial components, standing assembly



#### Cutting and bending machine TP 6 / V1 - standard

With the cutting and bending machine TP 6 / V taped axial components for standing mounting can be cut and bent.

The robust construction of the machine ensures a high level of reliability. Components with leads up to a diameter of 1.3 mm can be processed.

Different bending tools are used for different dimensions. The fine tuning of the dimensions is done via a knurled screw.

#### Technical data

Performance:	approx. 50,000 components per hour
Dimensions:	230 x 180 x 210 mm
Weight:	5 kg

#### TP 6 / V1 Standard

	P	L	F	D	d	A
Min. mm	2.54	-	3	0.5	0.5	2
Max. mm	fixed	15	8	3	0.8	6

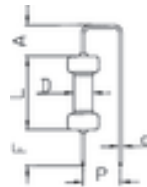

#### TP 6 / V1 with bending tool pitch 3.8 mm

	P	L	F	D	d	A
Min. mm	3.8	-	3	0.5	0.5	2.5
Max. mm	fixed	15	8	5	0.8	6

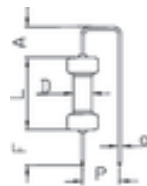

#### TP 6 / V1 with bending tool pitch 5.08 mm

	P	L	F	D	d	A
Min. mm	5.08	-	3	0.5	0.5	3
Max. mm	fixed	15	8	8	0.8	7

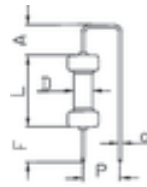

#### dpvlink 5207

Article Type

415.400 **TP 6 / V1 - Standard**  
Cutting and bending machine, standing assembly,  
P = 2.54 mm, wire thicknesses 0.5 - 0.8 mm

415.430.V1 **Additional bending tool P = 3.8 mm**  
standing assembly



dpvlink 5207



Article Type

415.435.V1 **Additional bending tool P = 5.08 mm**  
standing assembly

415.439 **Holder for additional bending tool**  
(for an easy conversion)

**Accessories**



415.800 **BR6 reel holder**



415.815 **CS 30 feeding unit / loose components**  
(for TP6 / V)



415.825 **M adjustable motor drive**



415.835.1 **TNS/1 waste tape ejector**  
(for TP/6, TP6/S, TP6/V, TP6/PR-B, TP6/R)

## Radial components

### VARIOCUT

#### Cutting device for radial taped components

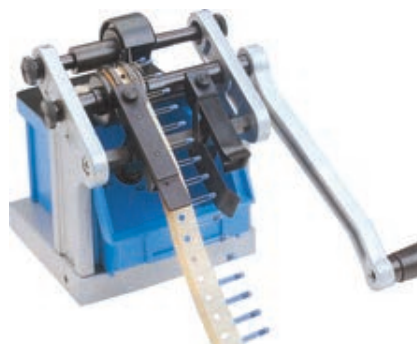

The proven cutting device VARIOCUT cuts all kinds of radial taped components to the required length. Therefore, a recutting of the leads is not necessary after soldering. The VARIOCUT is based on the successful CUTBEND principle and is characterized by an easy handling, a high performance and a favorable price. The VARIOCUT is handy and can be mounted on each table by the included screw clamp.

#### Technical data

Dimensions without crank:	175 x 145 x 160 mm (LxWxH)
Crank length:	160 mm
Weight:	1.9 kg
Performance:	up to 40,000 components per hour

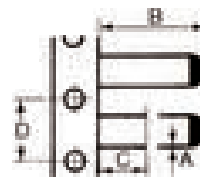

#### Working dimensions:

Head type	A	B	C	D
12.7	0.5-0.8 mm	max. 35 mm	1.0-8.0 mm	12.7 mm
15.0	0.5-0.8 mm	max. 35 mm	1.0-8.0 mm	15.0 mm

dpvlink 5106



Article Type

405.500 **VARIOCUT, tape pitch 12.7 mm**

405.501 **Pin wheel for tape pitch 15 mm**

## TP 6 / R-EC - OLAMEF

Cutting machine for taped radial components

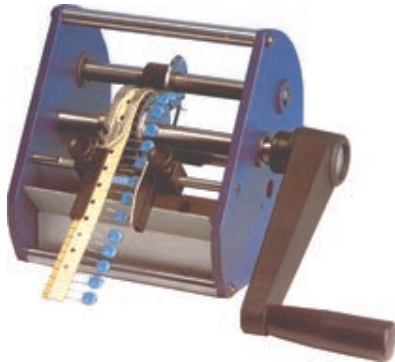

simple construction, no cover, no motor connection possible

Cutting machine TP 6/R-EC cuts taped radial components. Construction and reliability as with all TP 6 machines.

### Technical data

Performance:	approx. 20,000 components per hour
Dimensions:	230 x 180 x 210 mm
Weight:	4 kg

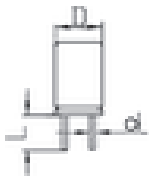

### TP 6/R - EC - Standard

	L	d	D
Min. mm	2	0.4	1
Max. mm	10	1	14

dpvlink 5124



Article	Type
415.600.EC	<b>TP 6/R-EC standard P = 12.7 mm</b> Cutting machine for wire thicknesses Ø 0.4 - 1.0 mm, Tape pitch pattern P = 12.7 mm
415.601.EC	<b>TP 6/R-EC, P = 15 mm</b> Cutting machine for wire thicknesses Ø 0.4 - 1.0 mm, Tape pitch pattern P = 15 mm

## TP 6 / R - OLAMEF

Cutting machine for taped radial components



With the cutting machine TP 6 / R taped radial components can be cut.

Construction and reliability is the same as with all TP 6 machines.

An adjustable motor drive and a waste tape ejector are available as accessories.

### Technical data

Performance:	approx. 20,000 components per hour
Dimensions:	230 x 180 x 210 mm
Weight:	4 kg

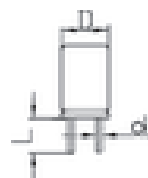

	L	d	D
Min. mm	2	0.4	1
Max. mm	10	1	14

dpvlink 5319



Article	Type
415.600	<b>TP 6 / R P = 12.7 mm</b> Cutting machine for taped radial components, tape pitch pattern P = 12.7 mm, standard
415.601	<b>TP 6 / R P = 15 mm</b> Cutting machine for taped radial components, tape pitch pattern P = 15 mm, standard

### Accessories

415.800 **BR6 reel holder**



415.825 **M adjustable motor drive**



## TP / TC 4 - OLAMEF

### Cutting machine for loose radial components



Loose radial components can be cut with the TC 4 cutting machine.

The feeding is easy and fast. The processing speed is steplessly adjustable. The cutting length can be set with the adjustable guide. The robust design ensures a reliable and durable operation.

Taped components can also be processed with the reel holder BR 3 (option). The reel holder is simply attached to the cutting machine.



#### Technical data

Performance:	approx. 3,000 components per hour (in connection with BR 3 approx. 15,000 components / hour)
Dimensions:	200 x 470 x 270 mm
Weight:	12 kg
Motor:	220 V / 50 Hz - 50 VA

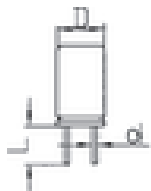

	L	d	D
Min. mm	3	0.4	1
Max. mm	12	0.8	15

#### dpvlink 5335

Article	Type
415.910	<b>TP / TC 4 cutting machine</b> for loose radial components, for wire thicknesses $\varnothing$ 0.4 - 0.8 mm
415.911	<b>BR 3/12.7 tape guide TC 4</b> for taped radial components, tape pitch pattern P = 12.7 mm
415.912	<b>BR 3/15 tape guide TC 4</b> for taped radial components, tape pitch pattern P = 15 mm

## Accessories for TP 6 - machines

The accessories for each TP machine are ideal for the optimum utilization of the individual devices. All accessories are available as an option to the individual devices.

### BR6 Reel holder



#### dpvlink 5524

Article

415.800 **BR6 reel holder**



### TNS Waste tape ejector



#### dpvlink 5525

Article

415.835.1 **TNS/1 waste tape ejector**  
(for TP/6, TP6/S, TP6/V, TP6/PR-B, TP6/R)

415.835.3 **TNS/13 waste tape ejector**  
(for TP6/V-PR, TP6/PR-F)



### CS Feeding unit for loose components



#### dpvlink 5163

Article

415.805 **CS 10 feeding unit / loose components**  
(for TP6, TP6 / PR-B, TP6 / S)

415.810 **CS 20 feeding unit / loose components**  
(for TP6 / V-PR)

415.815 **CS 30 feeding unit / loose components**  
(for TP6 / V)

415.820 **CS 40 feeding unit, loose components**  
(for TP6 / PR-F)



### M Adjustable motor drive



#### dpvlink 5523

Article

415.825 **M adjustable motor drive**  
415.825.1 **M/1 adjustable motor drive**  
(for TP6 / PR-F, TP6 / V-PR)



### Feeder / component body type 200240



#### dpvlink 13342

Article

415.200240 **Feeder / component body type 200240**  
for taped components suitable for  
TP 6.EC; TP 6.97; TP6 PR-B;  
TP6 / PR-B/97; TP 6/S; TP6





## Pneumatic cutting machines

### TP / LN 100 - OLAMEF

Pneumatic cutting machine for loose radial components

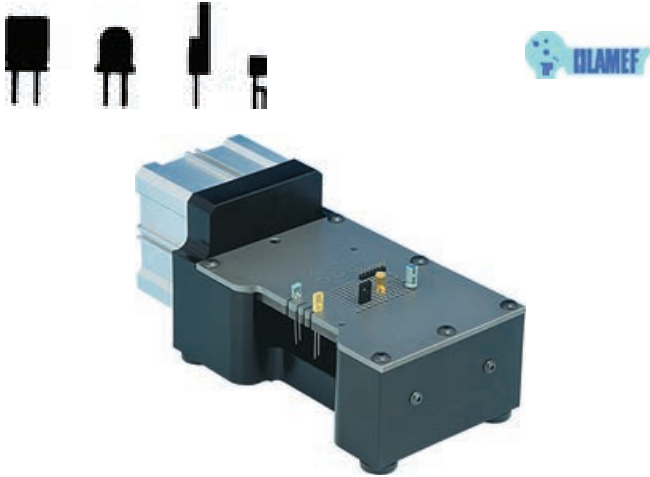

With the pneumatic cutting machine TP / LN-100 the leads of loose radial components can be cut exactly.

The precise mechanism ensures a straight cut without causing an edge or a deformation of the wire surface.

The robust construction allows the simultaneous cutting of several components. The cutting process starts after pressing the foot switch. An adapter plate as well as several special cutting plates are available on customer's request.

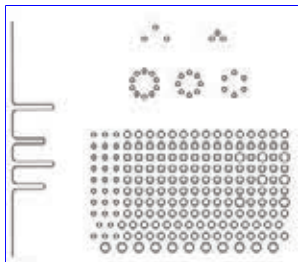

#### Technical data

Performance:	up to 3,000 components per hour
Dimensions:	210 x 100 x 100 mm
Weight:	3 kg
Air connection:	6 bar
Cutting length:	3.2 mm (other lengths on request)

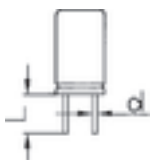

	L	d
Min. mm	3.2	0.3
Max. mm	fixed	1

#### dpwlink 5385

Article	Type
415.900	<b>TP / LN-100 standard</b> Cutting machine for loose radial components, cutting length L = 3.2 mm, for wire thicknesses from 0.3-1.0 mm
415.900.S	<b>TP / LN-100 customized</b> (with special cutting plate)
415.901	<b>Adapter plate for TP / LN-100</b> for longer cutting lengths

### TP / LN-500 - OLAMEF

Pneumatic cutting machine for loose radial components



The TP/LN-500 cuts with an inclined cutting blade and allows the cutting of wire thicknesses of up to a diameter of 1.3 mm.

#### Technical data TP/LN-500/1 standard

Performance:	up to 3,000 components per hour
Dimensions:	250 x 100 x 100 mm
Weight:	5 kg
Air connection:	6 bar
Cutting length:	3.2 mm (other lengths on request)

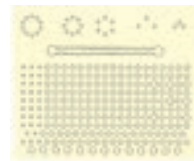

Schneidplatte LN 500 standard

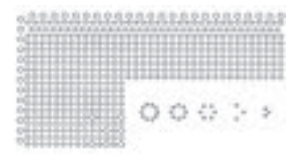

Sonderschneidplatte LN 500.2

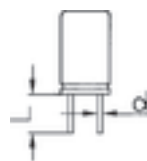

	L	d
Min. mm	3.2	0.3
Max. mm	fixed	1.3

#### dpwlink 5392

Article	Type
415.905	<b>TP / LN-500 - standard</b> Cutting surface 52 x 43 mm Cutting length L = 3.2 mm
415.905.S	<b>TP / LN-500 - customized</b> (with special cutting plate)
415.906	<b>Adapter plate for TP / LN-500</b> for longer cutting lengths
415.907	<b>TP / LN-500.2</b> Cutting surface 52 x 93 mm Cutting length L = 3.2 mm
415.907.S	<b>TP / LN-500.2 - customized</b> (with special plate)
415.908	<b>Adapter plate for TP / LN-500.2</b> for longer cutting lengths



## TP / TS 1 - OLAMEF

### Pneumatic cutting and crimping machine for loose radial components

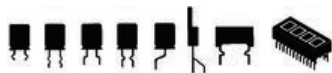

The pneumatic cutting and crimping machine TP/TS1 can be used for the cutting and bending of loose radial components.

The feeding of the components takes place manually by vertical insertion of leads into the firmly mounted matrix. The cutting process is started by pressing the foot switch. The cutting and the forming of the leads is made quickly and precisely.

The machine can be equipped with tools for various processing possibilities. The individual tools can be easily exchanged.

#### Technical data

Performance:	approx. 2,000 components per hour
Dimensions:	390 x 230 x 140 mm
Weight:	13 kg
Air connection:	6 bar

#### dpvlink 5418

Article Type

415.927.G

#### TP / TS 1

Pneumatic cutting and crimping machine for radial loose components, basic unit (without tools)



### Tool stand-off / snap-in



	a	b	c	d	D
Min. mm	5	2	1.4	0.4	1
Max. mm	15	12	fixed	0.8	15

#### dpvlink 6157

Article Type

415.928.180600

#### Tool stand-off / snap-in

P = 2.54 / 5.08 / 7.62 / 10.16 mm



### Cutting tool

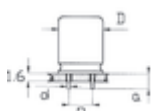

	a	d	D
Min. mm	3	0.4	1
Max. mm	13	0.8	15

#### dpvlink 6161

Article Type

415.928.181000

#### Cutting tool

P = 2.54 / 5.08 / 7.62 / 10.16 mm



### Tool diode 4 leads stand-off

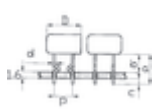

	a	b	c	d	D
Min. mm	6	4	1.4	0.4	1
Max. mm	14	12	fixed	0.8	15

#### dpvlink 6162

Article Type

415.928.181100

#### Tool diode with 4 leads stand-off

P = 5.08 mm



### LED tool polarity stand-off /snap-in

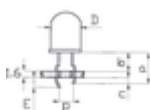

	a	b	c	d	D
Min. mm	5	2	1.4	2	2.4
Max. mm	15	12	fixed	5	fixed

#### dpvlink 6163

Article Type

415.928.181200

#### LED tool polarity stand-off /snap-in

P = 2.54 mm



### Tool 90° bend and cut

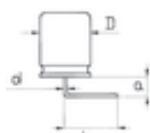

	a	b	d	D
Min. mm	3	6	0.4	1
Max. mm	8	fixed	0.8	15

#### dpvlink 6164

Article Type

415.928.181300

#### Tool 90° bend and cut



### Tool TO-220, center lead

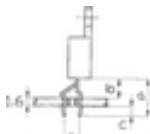

	a	b	c	p
Min. mm	7	4	1.4	2.54
Max. mm	13	10	fixed	fixed

#### dpvlink 6172

Article Type

415.928.182300

#### Tool TO-220

center lead spread, crimp / cut



### Tool TO-220, in-line stand-off / snap-in

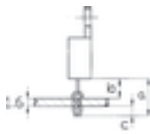

	a	b	c
Min. mm	6	3	1.4
Max. mm	11	8	fixed

#### dpvlink 6173

Article Type

415.928.182400

#### Tool TO-220 in-line stand-off / snap-in



### Tool TO-92, center lead

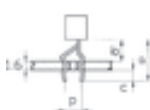

	a	b	c	p
Min. mm	7	4	1.4	2.54
Max. mm	13	10	fixed	fixed

#### dpvlink 6176

Article Type

415.928.182700

#### Tool TO-92, center lead

spread, cut, crimp



Further tools are online available

## Cut-off saw

### Cut-off saw Olamef



For the cutting of female connectors and plug connectors with grooves.

Simple and quick conversion to different sizes. The stop with detent and additional fine adjustment for lengths of 1 to 32 pins. A hold-down clamp for a reliable positioning. DC motor with speed control for a optimal cutting performance.

Robust construction for a precise cutting in continuous operation.

The number of the cuts is recorded with an 8-digit digital LCD display.

#### Technical data

Saw blade material:	HSS
External diameter:	63 mm
Thickness:	0.25 mm
Material cut:	
Width max.	12 mm
Height max.	8 mm
Sawn strip length:	1 - 32-pin
Grid spacing:	2.54 mm
Operating temperature	15°C - 25°C
Power supply:	110 or 220 V ^ 50-60 Hz
Weight:	10.0 kg

The products meet the safety requirements of the EC directives. An EC declaration of conformity is supplied with the devices.

#### Scope of delivery:

Strip saw, saw blade, key set, power cable, cutter tray and user manual

[dpvlink 13364](#)

Article	Type
---------	------

415.1090002	<b>Cut-off saw Olamef</b>
-------------	---------------------------

415.1090011	<b>Saw blade (for strips saw SEP-4/Olamef)</b>
-------------	--



## Component counting devices

### County EVO

Component counting device for axial, radial and SMD components



County EVO, the digital counting device with micro computer is used to count the number of taped axial, radial and SMD components

- counting in both directions (left or right)
- division factor 1 to 19 (and 2,3,4 multiplication factor for 0402, 0201 and 01005 components)
- totalizer mode
- preset mode counting (with audible alarm when the desired component number is reached)
- calibration test and self-diagnostics
- memory for the last chosen quantity
- Model 400.013 with rechargeable battery, connection for barcode reader, printer / PC outlet, clock and data logger for the last 500 countings



#### Technical data

min. Ø of the lead:	0.4 mm
Axial tape width:	55-110 mm
Radial tape width:	18 mm
maximum Ø of the components:	14 mm
Display 4-digit:	height 13 mm
Dimensions:	240 x 130 x 110 mm
Weight:	1.8 kg

[dpvlink 5067](#)

Article	Type
---------	------

400.011	<b>County EVO, counting device 100 - 240 V / 50-60 Hz</b>
---------	---

400.013	<b>County EVO, counting device 220 V / 50-60 Hz with rechargeable battery, auxiliary relay and printer output</b>
---------	---

400.020	<b>Adapter for taped SMD components</b>
---------	---

400.023	<b>Reel stand for axial/radial components</b>
---------	---

400.025	<b>Handle for reels</b>
---------	-------------------------

400.027	<b>Unroll stand for SMD components</b>
---------	--

400.027.1	<b>Crank for SMD reel stand</b>
-----------	---------------------------------



## County S EVO

**Motorized component counting device for SMD components**



The motorized component counter County-S EVO for SMD components offers two operation options:

### 1. Totalizer

The components are counted from zero by the motorized device. The counter stops automatically at the end of the tape for not losing the point of reference.



### 2. Preset mode

The component counter stops automatically when reaching the quantity manually set by the operator.

All functions of the device are supported by an interactive graphics display and easy to execute.

The counting display shows the following data:

- counting direction
- number of holes per component
- counting mode (total, preset quantity and rewinding)
- operator's name
- counting
- date and time (or recorded barcode)

### Technical data

Display:	6 LED digits (height approx. 14 mm)
Maximum counting speed:	220 components/sec, (1 component per hole)
Accuracy:	+/-1 component/1000
Number of holes per component:	1-99 (division factor)
Maximum height of the tape:	56 mm
Max. reel diameter:	400 mm (with support 400, 150 and 650 mm)

- adjustable feeding speed
- Step-by-Step feeding (each single component)
- input for barcode reader
- Option 'no component'
- Connection for printer / PC
- Operator identification (max. 10 persons, 8 alphanumeric characters each)
- Internal clock (1 week backup)
- Data logger saves the last 500 countings
- Totalizing of part countings
- two lateral handles for transportation

### dpvlink 5079



Article	Type
400.100	<b>County-S EVO counting device 220 / 240 V, 50-60 Hz</b>
400.103	<b>County-S EVO counting device 220 / 240 V, 50-60 Hz with Empty-Pocket-Check</b>
400.110	<b>Aluminum empty reel for County S EVO</b>
400.150	<b>Footplate/support for rolls diameter &gt; 400 mm</b>

### Accessories for County EVO and County S EVO



### dpvlink 19245



Article	Type
400.155	<b>Barcode reader</b> with spiral cable, wide-angle scanner especially to read wide barcodes with small distance (degree of protection IP42).  The barcode reader is connected with the EVO counting device by means of a single connector and supplied via the same cable.
400.095	<b>Thermal printer</b> with power supply unit 110 / 220 VAC and signal cable.  The EVO counting device is optimized for printing labels 57 x 51 mm.
400.096	<b>Label roll</b> with 1360 labels 57x51 mm

## Component counting balances



The brand KERN stands for precision and reliability. KERN is a specialist for accurate weighing having more than 160 years of experience. The products are of an excellent manufacturing quality, extremely robust and durable, and are characterized by an easy handling.



**Adjusting program CAL:**  
Adjusting program CAL: For quick setting up of the balance's accuracy. External adjusting weight required



**Data interface RS-232:**  
To connect the balance to a printer, PC or network



**GLP/ISO log:**  
With weight, date and time. Only with KERN printers



**KERN Communication Protocol (KCP):**  
It is a standardized interface command set for KERN balances and other instruments



**Piece counting:**  
Reference quantities selectable. Display can be switched from piece to weight



**Recipe level A:**  
The weights of the recipe ingredients can be added together and the total weight of the recipe can be printed out



**Totalising level A:**  
The weights of similar items can be added together and the total can be printed out



**Percentage determination:**  
Determining the deviation in % from the target value (100 %)



**Weighing units:**  
Can be switched to e.g. nonmetric units. See balance mode.



**Hold function:**  
(Animal weighing program) When the weighing conditions are unstable, a stable weight is calculated as an average value



**Suspended weighing:**  
Load support with hook on the underside of the balance



**Weighing with tolerance range:**  
(Checkweighing) Upper and lower limits can be programmed individually



**Battery operation:**  
Ready for battery operation. The battery type is specified for each device



**Universal plug-in power supply:**  
with universal input and optional input socket adapters for EU, CH, GB



**Universal plug-in power supply:**  
with universal input and optional input socket adapters for EU, CH, GB, USA



**Weighing principle: Strain gauges**  
Electrical resistor on an elastic deforming body

## Precision balance KERN PCB



Compact precision balance for the use in laboratories

- **PRE-TARE function** for manual subtraction of a known container weight
- **Freely programmable weighing unit**
- **Recipe function** allows for the weighing of different ingredients of a mixture.
- **Plus/minus weighing procedures**

### Technical Data:

Display:	backlit LCD display
Net weight:	approx. 1.1 kg
Dimensions:	163 x 245 x 79 mm (WxDxH)
Power supply:	230 V / 50 Hz or rechargeable battery (optional)
Ambient temperature:	+5°C to +35°C
Test weight:	optional



**Battery operation (optional):** rechargeable battery set external, operating time up to 48 h, charging time approx. 8 h (art. no. 401.PCB-A01)

Article	Readability	Reproducibility	Weighing range	Linearity	Min. component weight
401.PCB100-3	0.001 g	0.001 g	100 g	0.003 g	0.02 g
401.PCB250-3	0.001 g	0.001 g	250 g	0.005 g	0.02 g
401.PCB350-3	0.001 g	0.002 g	350 g	0.005 g	0.02 g
401.PCB200-2	0.01 g	0.01 g	200 g	0.02 g	0.2 g
401.PCB1000-2	0.01 g	0.01 g	1.0 kg	0.03 g	0.2 g
401.PCB2500-2	0.01 g	0.01 g	2.5 kg	0.05 g	0.2 g
401.PCB3500-2	0.01 g	0.02 g	3.5 kg	0.05 g	0.2 g
401.PCB1000-1	0.1 g	0.1 g	1.0 kg	0.2 g	2.0 g
401.PCB2000-1	0.1 g	0.1 g	2.0 kg	0.2 g	2.0 g
401.PCB6000-1	0.1 g	0.1 g	6.0 kg	0.3 g	2.0 g

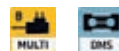

dpvlink 16089



Article	Type	Weighing plate [mm]
401.PCB100-3	Precision balance KERN PCB 100-3	Ø 81
401.PCB250-3	Precision balance KERN PCB 250-3	Ø 81
401.PCB350-3	Precision balance KERN PCB 350-3	Ø 81
401.PCB200-2	Precision balance KERN PCB 200-2	Ø 105
401.PCB1000-2	Precision balance KERN PCB 1000-2	130x130
401.PCB2500-2	Precision balance KERN PCB 2500-2	130x130
401.PCB3500-2	Precision balance KERN PCB 3500-2	130x130
401.PCB1000-1	Precision balance KERN PCB 1000-1	130x130
401.PCB2000-1	Precision balance KERN PCB 2000-1	130x130
401.PCB6000-1	Precision balance KERN PCB 6000-1	150x170

-for DKD calibration certificate and rechargeable battery see accessories-

## Counting balance KERN CPB



Professional model with a counting resolution of up to 60,000 points

- **Counting results memory** for adding up the individual countings, result is shown in total quantity and total weight
- **Target quantity programmable** for checkweighing with acoustic signal
- **Large LCD display** with a digit height of 20 mm, backlighting 3-fold adjustable: permanently on, in case of load exchange on for 3 seconds and permanently off.
- **High mobility** due to operation with rechargeable battery (optional), compact, flat design and low weight
- **3 displays** for totalweight, piece weight and total quantity
- **PRE-TARE function** for manual subtraction of a known container weight
- **Precise counting:** automatic optimization of reference weight for a gradual improvement of the average piece weight value

### Technical data:

Display:	backlit LCD display, 3-fold adjustable
Net weight:	approx. 4.0 kg
Dimensions:	315 x 355 x 110 mm (WxDxH)
Weighing plate:	295 x 225 mm
Power supply:	230 V / 50 Hz or rechargeable battery (optional)
Ambient temperature:	0°C to +40°C
Test weight:	optional

 **Battery operation (optional):** rechargeable battery set internal, operating time up to 90 h, charging time approx. 12 h (art. 401.GAB-A04)

Article	Readability	Reproducibility	Weighing range	Linearity	Min. component weight
401.CPB-6K0.1N0	0.1 g	0.2 g	6,0 kg	0.4 g	1.0 g
401.CPB-15K0.2N0	0.2 g	0.4 g	15 kg	0.8 g	2.5 g
401.CPB-30K0.5N0	0.5 g	1.0 g	30 kg	2.0 g	5.0 g

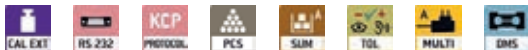

### dpwlink 8246

Article	Type
401.CPB-6K0.1N	Counting balance KERN CPB-6K0.1N
401.CPB-15K0.2N	Counting balance KERN CPB-15K0.2N
401.CPB-30K0.5N	Counting balance KERN CPB-30K0.5N

**-for DKD calibration certificate and rechargeable battery see accessories-**

## DKD calibration certificate



DKD calibration certificate for balances. Created by the KERN calibration laboratory (accredited by the German Calibration Service (DKD)) with international validity.

### dpwlink 8280

Article	Type
401.963-127	<b>DKD calibration certificate DKD</b> for balances with a weighing capacity up to 5 kg
401.963-128	<b>DKD calibration certificate</b> for balances with a weighing capacity from 5 kg to 50 kg
401.963-129	<b>DKD calibration certificate</b> for balances with a weighing capacity from 50 kg to 350 kg

## Rechargeable battery for KERN balances



Rechargeable battery set, depending on model external or internal.

### dpwlink 8276

Article	Type
401.GAB-A04	Rechargeable battery operation internal for model CPB
401.PCB-A01	Rechargeable battery operation internal for model PCB

## Balance Connection - Software SCD-4.0



**For the direct transfer of weighing data to Windows applications** (operating systems XP, Vista and Windows 7).

- Transfer via RS 232 to the PC, e.g. to MS Excel
- Transfer by pressing a button or time-controlled
- Date / time can also be displayed
- Interface protocols for KERN balances are already predefined
- Interface cable is included (please indicate model when ordering)

### Advantages:

- Typing errors are avoided
- GLP compliant laboratory software

### dpwlink 15682

Article	Type
401.SCD-4.0	<b>Balance Connection - Software SCD-4.0</b>